

## Viper Maxi MK II Wire Rope Lubricator

Page | 1



Manufactured & Distributed by

**LUBRICATION**  
**ENGINEERING**



## Contents

<b>1.0 Introduction .....</b>	<b>3</b>
<b>2.0 Viper Maxi MKII Kit Components .....</b>	<b>4</b>
<b>3.1 Viper Maxi MKII Standard Kit.....</b>	<b>6</b>
3.1.1 Viper Maxi MKII Complete 180KG Kit.....	6
3.1.2 Viper Maxi MKII Complete 180KG Pump Kit .....	7
3.1.3 Viper Maxi MKII Complete 180KG Hose .....	8
<b>3.2 Viper Maxi MKII High Flow Kit .....</b>	<b>9</b>
3.2.1 Viper Maxi MKII Complete 180KG HF Kit .....	9
3.2.2 Viper Maxi MKII Complete 180KG HF Pump Kit .....	10
3.2.3 Viper Maxi MKII Complete 180KG HF Hose .....	11
<b>4.0 Viper Maxi MKII Assembly Instructions .....</b>	<b>12</b>
<b>5.0 Ratchet Strap Buckle Assemblies .....</b>	<b>15</b>
<b>6.0 Viper Maxi MKII WRL Operating Instructions .....</b>	<b>16</b>
<b>7.0 Lubricant Penetration .....</b>	<b>18</b>
<b>8.0 Equipment Specifications .....</b>	<b>19</b>
<b>9.0 Trouble Shooting .....</b>	<b>20</b>
<b>10.0 Caution Level Rating .....</b>	<b>21</b>
<b>11.0 Danger Rating .....</b>	<b>22</b>
<b>12.0 Viper Maxi MKII WRL Guarantee.....</b>	<b>23</b>



## 1.0 Introduction

The **VIPER MAXI MK II** Wire Rope Lubricator is an Australian designed and built lubricator for wire rope sizes from 50mm (2") to 165mm (6-1/2"). It provides fast and effective single pass lubrication of wire ropes, eliminating the slow and arduous task of manual lubrication. Lubrication of wire ropes with the Viper system provides superior protection against corrosion and fretting wear by forcing lubricant into the core of the wire rope while also coating the outer strands. The use of the Viper Maxi MKII WRL improves operator safety and reduces the environmental impact of wire rope lubrication for any size operation.

Page | 3

### 1.1 Key features of the Viper Maxi MKII WRL include:

1. Viper collar constructed from high grade aluminium with a high visibility corrosion resistant coating.
2. New Viper collar is constructed of light weight material and incorporates cast carry handles for easier handling.
3. Unique polyurethane seal design provides largest pressure contact area to ensure maximum lubricant penetration.
4. Durable and wear resistant polyurethane seals last thousands of metres in normal service.
5. Seal and scraper size range to cater for rope sizes 50mm to 165mm.
6. The Viper Maxi MKII Standard Kit: 45:1 grease pump delivers lubricant at up to 4.5kg per minute and pressures up to 5,000 psi.  
The Viper Maxi MKII High Flow Kit: High pressure high flow 50:1 grease pump delivers lubricant at up to 13kg per minute and pressures up to 5,500 psi.
7. Global distribution network which provides local customer support.

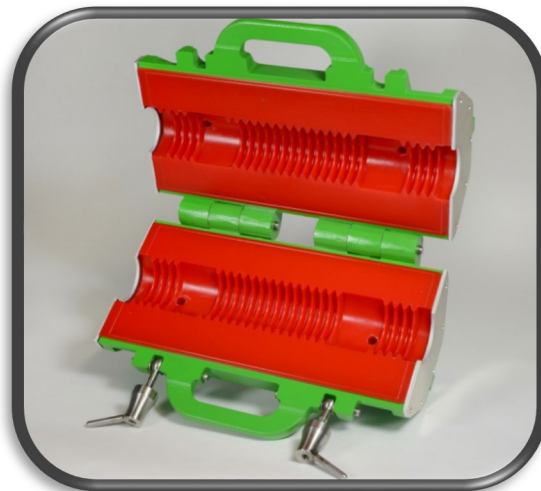

## 2.0 Viper Maxi MKII Kit includes the following components

1. Viper lubricator collar, cast aluminium with inbuilt handles, includes lubricant delivery line quick connect coupling and excess lubricant fitting.
2. High pressure high flow customised Viper 50:1 grease pump to suit 180kg drum which comes preassembled with:
  - a) Air control valve
  - b) Air regulator with gauge
  - c) High pressure grease flow control valve
  - d) Male quick connect fitting
3. Ten (10) metre, high pressure, 3/4" hydraulic hose complete with female quick connect couplings on each end.
4. One (1) metre clear hose for excess lubricant discharge.
5. Two (2) x 4 metre ratchet straps rated to 1200kg.
6. Four (4) x "Bow" shackles.
7. Viper collar shoulder carry strap.
8. Heavy duty aluminium storage case with stainless steel fixtures.
9. Polyurethane seals & Aluminium Scraper plates (ordered separately)
  - a) Sized to suit specific size ropes - 50mm (2") to 165mm (6 1/2")
  - b) Please reference the Seal, Scraper & Rope Cleaner Selection Guide for specific details.
10. Viper Wire Cleaners (recommended optional accessory)
  - a) Available to suit a variety of ropes – refer to Seal, Scraper & Rope Cleaner Selection Guide



## 3.0 Viper Maxi MKII Kit Components Assembled & Numbered Viper Maxi MKII Complete Collar

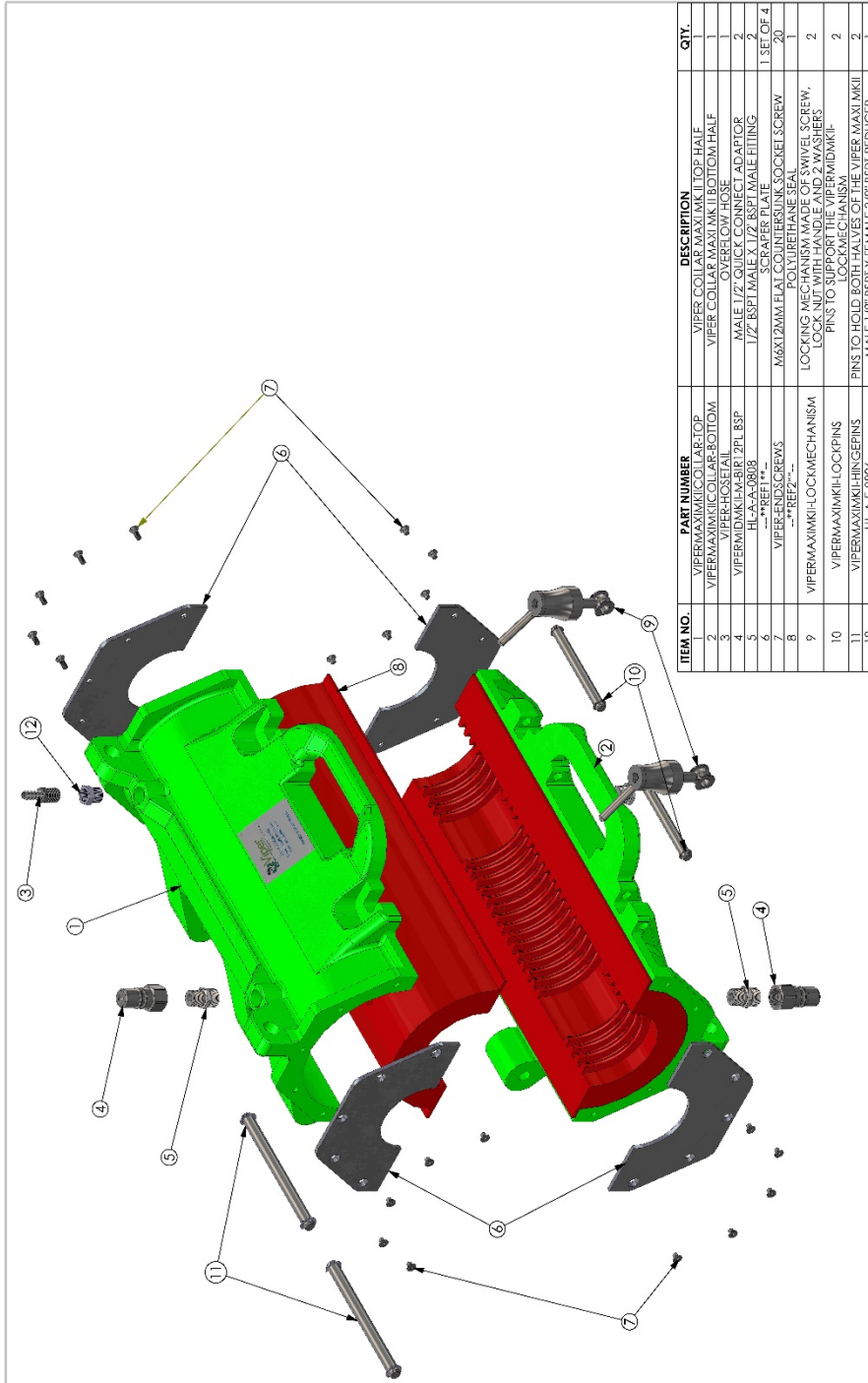

ITEM NO.	PART NUMBER	DESCRIPTION	QTY.
1	VIPERMAXIIMKII-COLLAR-TOP	VIPER COLLAR MAXI MKII TOP HALF	1
2	VIPERMAXIIMKII-COLLAR-BOTTOM	VIPER COLLAR MAXI MKII BOTTOM HALF	1
3	VIPER-HOSE-TAIL	OVERFLOW HOSE	1
4	VIPER-MID-MKII-MKII-2PHL-BSP	MALE 1/2" QUICK CONNECT ADAPTOR	2
5	VIPER-MID-MKII-MKII-2PHL-BSP	FEMALE 1/2" QUICK CONNECT ADAPTOR	2
6	VIPER-REF1**	1/2" BSP TUBULAR SCRAPER PLATE	1 SET OF 4
7	VIPER-ENDS-SCREWS	M6X12MM FLAT COUNTERSINK SOCKET SCREW	20
8	VIPER-REF2***	POLYURETHANE SEAL	1
9	VIPERMAXIIMKII-LOCKMECHANISM	LOCKING MECHANISM MADE OF SWIVEL SCREW, LOCK NUT WITH HANDLE AND 2 WASHERS	2
10	VIPERMAXIIMKII-LINKPINS	PINS TO HOLD BOTH HALVES OF THE VIPER MAXI MKII LOCK MECHANISM	2
11	VIPERMAXIIMKII-LINKGEFINS	PINS TO HOLD BOTH HALVES OF THE VIPER MAXI MKII	2
12	HL-A-E-0806	MALE 1/2" BSP T X FEMALE 3/8" BSP REDUCER	1

**\*\*REF1\*\*** : VIPER SEALS REFER TO THE VIPER SEAL AND SCRAPER SELECTION GUIDE  
**\*\*REF2\*\*** : VIPER SCRAPER PLATES REFER TO THE VIPER SEAL AND SCRAPER SELECTION GUIDE



## 3.1 Viper Maxi MKII Standard Kit

### 3.1.1 Viper Maxi MKII Complete 180KG Kit

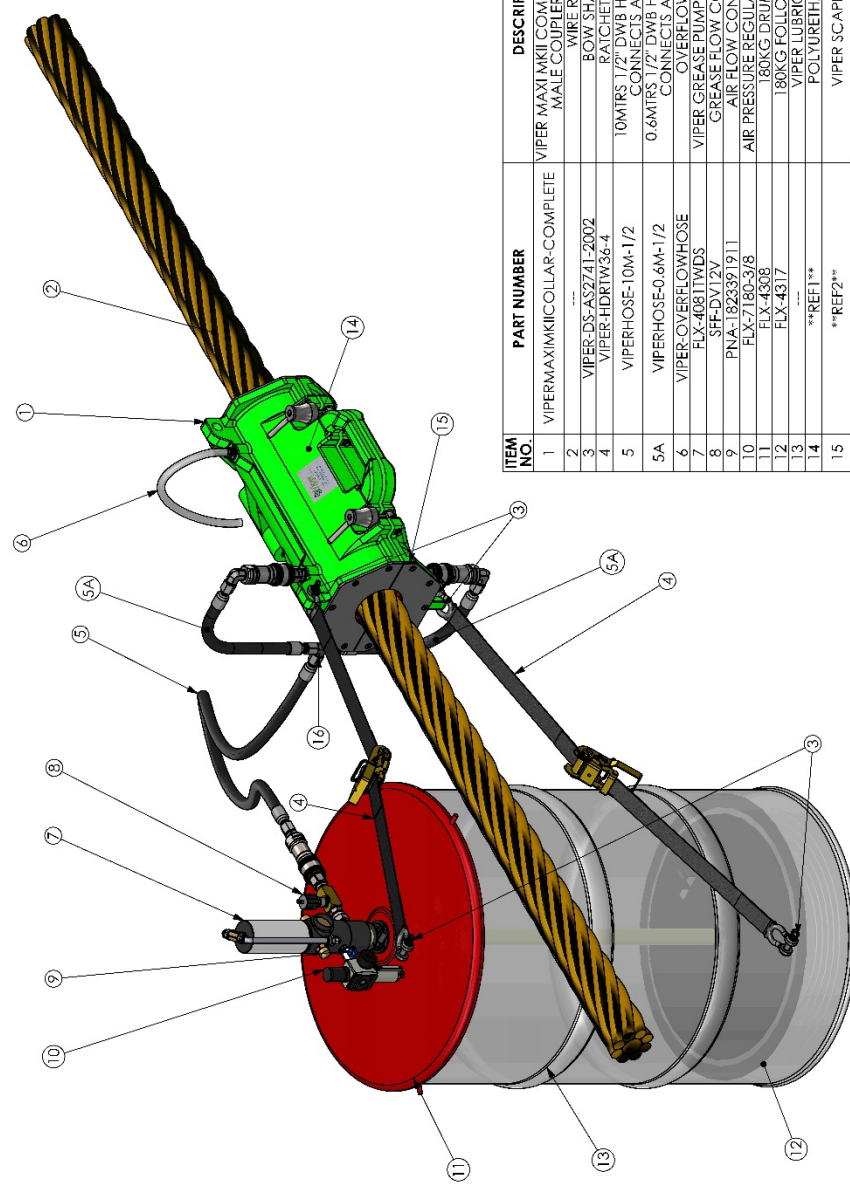

ITEM NO.	PART NUMBER	DESCRIPTION	QTY.
1	VIPERMAXIKICOLLAR-COMLETE	VIPER MAXI MKII COMPLETE WITH FITTINGS, MALE COUPLER AND PLUGS	1
2	---	WIRE SHACKLE	4
3	VIPER-DS-AS2741-2002	RAATCHET STRAP	2
4	VIPER-HDRW36-4	10MTRS 1/2" DWB HOSE WITH QUICK CONNECT AT ONE END	1
5	VIPERHOSE-10M4-1/2	0.6MTRS 1/2" DWB HOSE WITH QUICK CONNECT AT ONE END	2
5A	VIPERHOSE-0.6M-1/2	OVERFLOW HOSE	1
6	VIPER-OVERFLOWHOSE-FLX-40812W	VIPER GREASE PUMP 4.5 LTRS/MIN	1
7	---	GREASE FLOW CONTROL VALVE	1
8	---	AIR FLOW CONTROL VALVE	1
9	PNA-1923971911	AIR PRESSURE REGULATOR WITH GAUGE	1
10	FLX-7180-3/8	180KG DRUM COVER	1
11	FLX-4306	180KG FOLLOWER PLATE	1
12	FLX-4317	VIPER LUBRICANT PAIL	1
13	---	POLYURETHANE SEAL	1
14	**REF1**	VIPER SCAPPER PLATE	1 SET OF 4
15	**REF2**	TEE FITTING, 1/2" BSPT MALE (3)	1
16	HLA-A-060808	1/2" BSPT MALE X 1/2" BSPT MALE ELBOW	2
17	HLA-A-90-0808	---	1

**\*\*REF1\*\*** : VIPER SEALS REFER TO THE VIPER SEAL AND SCRAPER SELECTION GUIDE  
**\*\*REF2\*\*** : VIPER SCRAPER PLATES REFER TO THE VIPER SEAL AND SCRAPER SELECTION GUIDE

## 3.1.2 Viper Maxi MKII Complete 180KG Pump Kit

ITEM NO.	PART NUMBER	DESCRIPTION	QTY.
1	FLX-4081TWDS	VIPER GREASE PUMP 45:1 - 4.5 LTRS/MIN	1
2	HL-A-C-0808	1/2" BSPT MALE X 1/2" BSP FEMALE SWIVEL FITTING	1
3	SFF-DV12V	GREASE FLOW CONTROL VALVE	1
4	VIPERMIDMKII-M-BIR12PL BSP	1/2" BSP MALE QUICK COUPLER	1
5	HL-A-A-0808	1/2" BSPT MALE X 1/2" BSPT MALE FITTING	1
6	FLX-4308	180KG DRUM COVER	1
7	FLX-4317	180KG FOLLOWER PLATE	1
8	HL-A-A-0406	1/4" BSPT MALE X 3/8" BSPT MALE FITTING	1
9	PNA-1823891911	AIR FLOW CONTROL VALVE	1
10	FLX-7180-3/8	AIR PRESSURE REGULATOR WITH GAUGE	1
11	HL-A-A-0406	1/4" BSPT MALE X 3/8" BSPT MALE FITTING	1
12	-----	VIPER LUBRICANT PAIL	1

	
Viper Maxi MKII Complete 180 kg Pump Kit	
FIGURE	VIP-00280
REV	A1

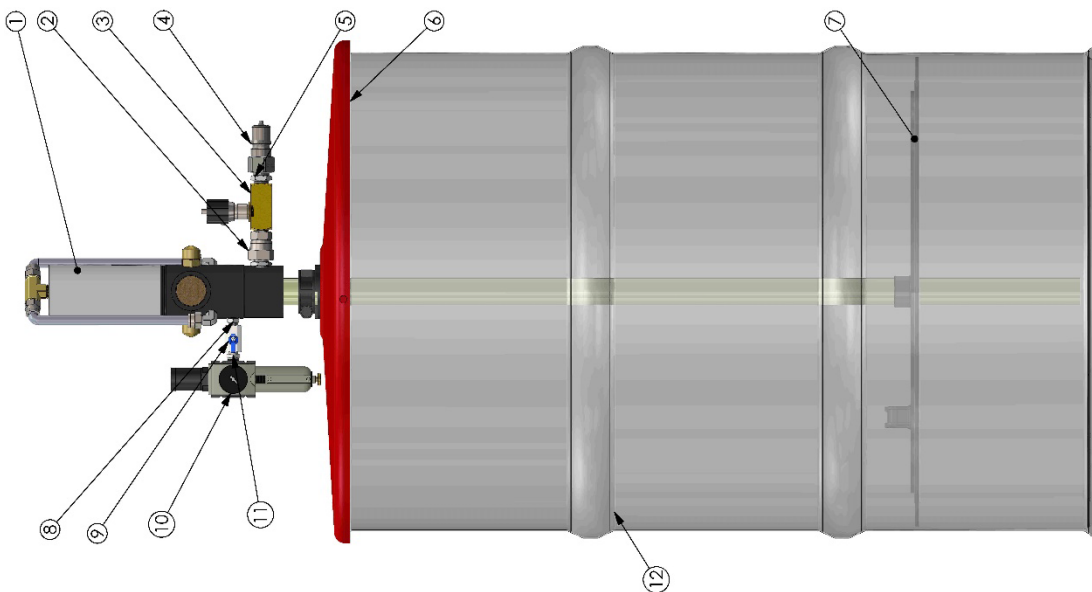

## 3.1.3 Viper Maxi MKII Complete 180KG Hose



ITEM NO.	PART NUMBER	DESCRIPTION	QTY.
1		10MTRS 1/2" DWB HOSE	1
2	HL-A-0808	1/2" BSPT MALE X 1/2" BSPT MALE FITTING	1
3	VIPERMAXII-F-BIR12PL BSP	1/2" QUICK CONNECT FEMALE ADAPTER	3
4		0.6MTRS 1/2" DWB HOSE	2
5	HL-A-90-0808	1/2" BSPT MALE X 1/2" BSPT MALE ELBOW	2

  

	
Viper Maxi MKII Complete 180 Kg Hose	
VIP-00280	A



## 3.2 Viper Maxi MKII High Flow Kit

### 3.2.1 Viper Maxi MKII Complete 180KG HF Kit

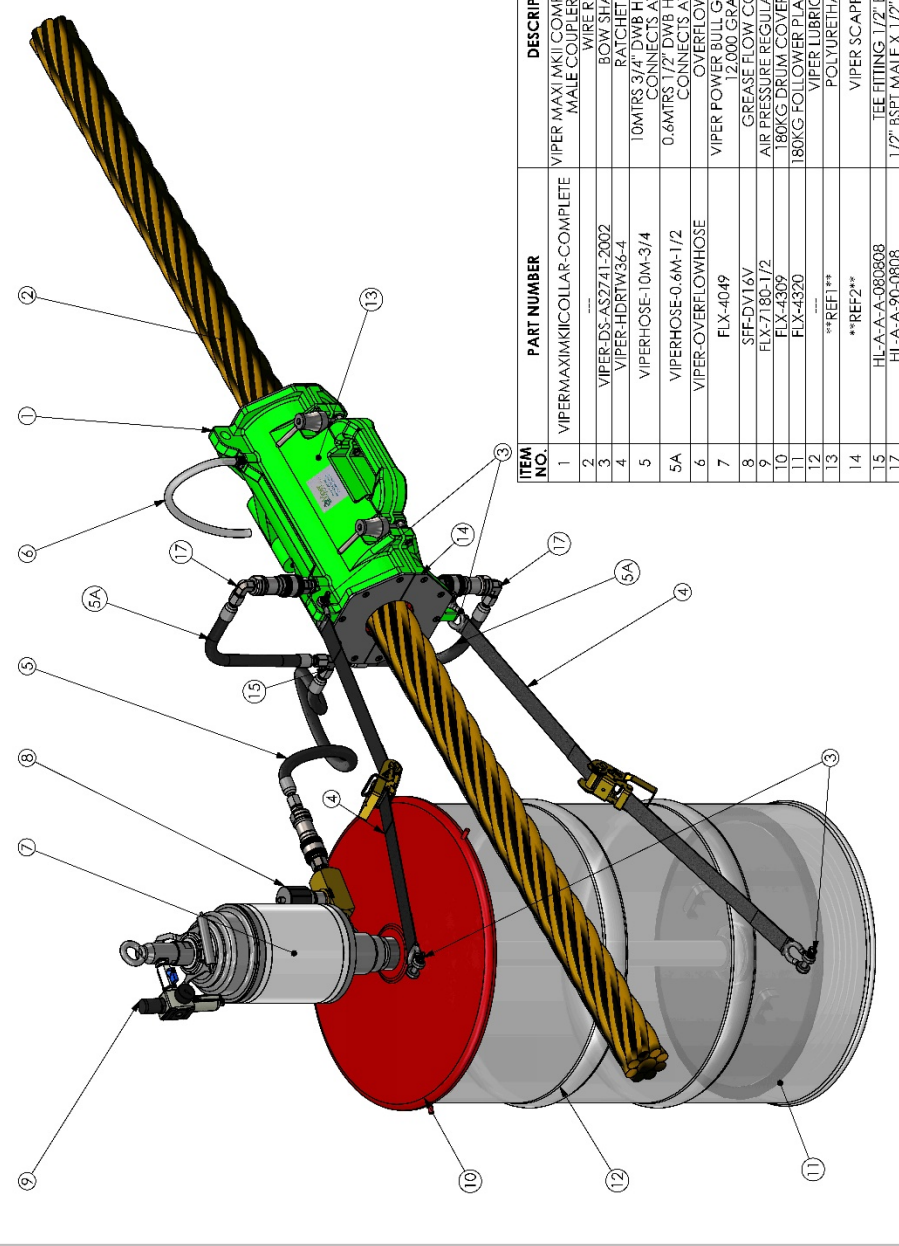

ITEM NO.	PART NUMBER	DESCRIPTION	QTY.
1	VIPERMAXIIKCOLLAR-COMLETE	VIPER MAXII MKII COMPLETE WITH FITTINGS, MALE COLLAR AND PLUGS	1
2		WIRE ROPE	1
3	VIPER-DS-AS274L-2002	BOW SHACKLE	4
4	VIPER-HDR1W36-4	RATCHET STRAP	2
5	VIPERHOSE-10M-3/4	10MTRS 3/4" DWB HOSE WITH QUICK CONNECTS ALONG END	1
5A	VIPERHOSE-0.6M-1/2	0.6MTRS 1/2" DWB HOSE WITH QUICK CONNECTS AT END	2
6	VIPER-OVERFLOWHOSE	OVERFLOW HOSE	1
7	FLX-4049	VIPER POWER BULL GREASE PUMP 50:1, 1/2" 800 GRAMS/MIN	1
8	SFFDV16V	GREASE FLOW CONTROL VALVE	1
9	FLX-7180-1/2	AIR PRESSURE REGULATOR WITH GAUGE	1
10	FLX-4309	180KG DRUM COVER TO SUIT FLX-4049	1
11	FLX-4330	180KG FOLLOWER PLATE TO SUIT FLX-4049	1
12		VIPER LUBRICANT PAIL	1
13	**REF1**	POLYURETHANE SEAL	1 SET OF 4
14	**REF2**	VIPER SCRAPPER PLATE	1 SET OF 4
15	HL-A-A-080808	TEE FITTING 1/2" BSPT MALE (3)	1
17	HL-A-A-90-0808	1/2" BSPT MALE X 1/2" BSPT MALE ELBOW	2

**\*\*REF1\*\*** : VIPER SEALS REFER TO THE VIPER SEAL AND SCRAPER SELECTION GUIDE  
**\*\*REF2\*\*** : VIPER SCRAPER PLATES REFER TO THE VIPER SEAL AND SCRAPER SELECTION GUIDE

## 3.2.2 Viper Maxi MKII Complete 180KG HF Pump Kit

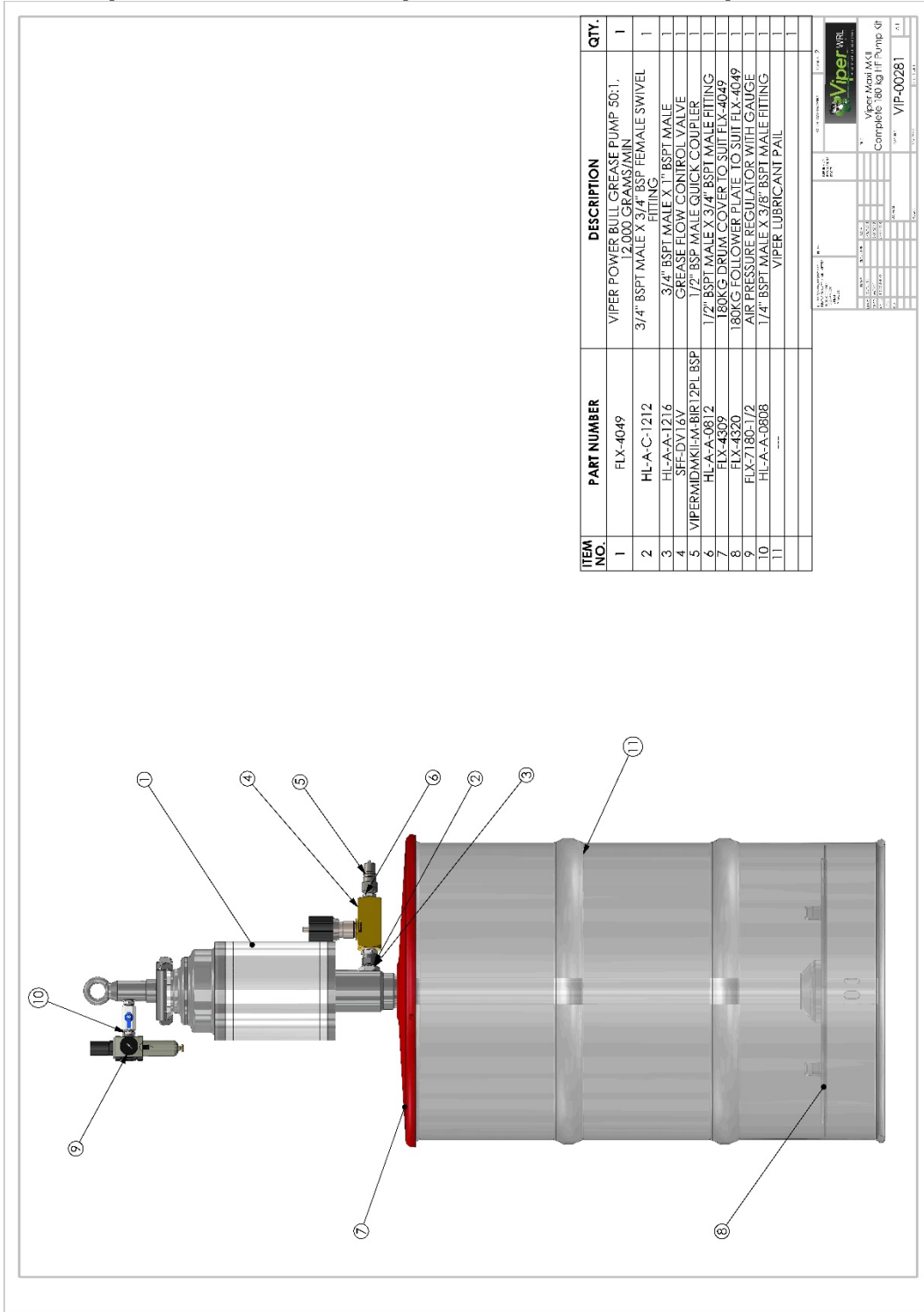

ITEM NO.	PART NUMBER	DESCRIPTION	QTY.
1	FLX-4049	VIPER POWER BULL GREASE PUMP 50:1, 12,000 CPM/MS MIN.	1
2	HL-A-C-1212	3/4" BSP MALE X 3/4" BSP FEMALE SWIVEL FITTING	1
3	HL-A-1216	3/4" BSPT MALE X 1" BSPT MALE GREASE FLOW CONTROL VALVE	1
4	SFF-DV16V	1/2" BSP MALE QUICK COUPLER	1
5	VIPERMIDMKII-M-BIRT2PL BSP	1/2" BSPT MALE X 3/4" BSPT MALE FITTING	1
6	HL-A-A-0812	180KG DRUM COVER TO SUIT FLX-4049	1
7	FLX-4320	180KG FOLLOWER PLATE TO SUIT FLX-4049	1
8	FLX-7180-1/2	AIR PRESSURE REGULATOR WITH GAUGE	1
9	HL-A-A-0808	1/4" BSPT MALE X 3/8" BSPT MALE FITTING	1
10	HL-A-A-0808	1/4" BSPT MALE X 3/8" BSPT MALE FITTING	1
11	HL-A-A-0808	VIPER LUBRICANT PAIL	1

	
Viper Maxi MKII Complete 180KG HF Pump Kit	
Part No.	VIP-00281
Rev.	1.0

## 3.2.3 Viper Maxi MKII Complete 180KG HF Hose



ITEM NO.	PART NUMBER	DESCRIPTION	QTY.
1		10MTRS 3/4" DWB HOSE	1
2	HL-A-0808	1/2" BSPT MALE X 1/2" BSPT MALE FITTING	1
3	VIPERMIDMKIIF-BIR1/2PL BSP	1/2" QUICK CONNECT FEMALE ADAPTER	3
4		0.6MTRS 1/2" DWB HOSE	2
5	HL-A-A-90-0808	1/2" BSPT MALE X 1/2" BSPT MALE ELBOW	2

	
Viper Maxi MKII Complete 180 Kg HF Hose	
REV:01	VIP-00280
A1	

## 4.0 Viper Maxi MKII Assembly Instructions (refer assembly video on website)

1. Remove all components from Viper aluminium carry case, unpack from packing materials and lay out on a flat surface. Check all items are present as per your purchase order.
2. Remove grease pump noting that the air inlet isolation valve, air regulator and high-pressure needle control valve are preassembled onto the pump.
  - Connect site specific compressed air connector to the air regulator. (not supplied)
3. Remove lid from lubricant container and place follower plate onto the top of the lubricant. Press down firmly until the follower plate comes in contact with the lubricant.
  - Note the Viper lubricator should only be used with high quality wire rope lubricants with a consistency of NLGI#00 to 2.
4. Fit the drum cover over the top of the lubricant container and tighten the three securing screws until they contact the container.
5. Clamp the grease pump handle onto the grease pump body and tighten the two screws.
6. Slide the grease pump shaft into the opening of the drum cover and the follower plate. Push the grease pump down into the grease until it touches the base of the grease container.
7. Connect the high-pressure grease hose to the grease pump outlet via the quick connect coupling.



8. Remove the Viper collar from the packaging materials and loosen the two clamping bolts allowing the collar to open.
9. Fit the scraper plates to the Viper collar using the counter sunk screws and the Allen key provided. Note scraper plates are sized to suit the wire rope as per the "Seal & Scraper plate selection guide".
10. Fit the Viper seals into the Viper collar. Note seals are sized to suit the wire rope as per the "Seal & Scraper Plate Selection Guide".
11. Clamp the lubricator collar fitted with seals and scrapers around the wire rope to be lubricated, tightening the two toggles.
  - Face the collar so that the hydraulic coupling is at the rope inlet end when the rope is being moved through the collar.
  - Locate the collar so that the optimum length of wire rope can be lubricated in a single pass, this is typically close to the winch drum.
12. Attach the clear plastic drain hose to the Viper collar. This hose is to deliver excess lubricant back to a collection container.
13. Connect the high-pressure lubricant delivery hose to the Viper Collar using the quick connect coupler.

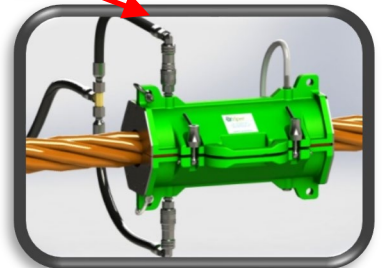
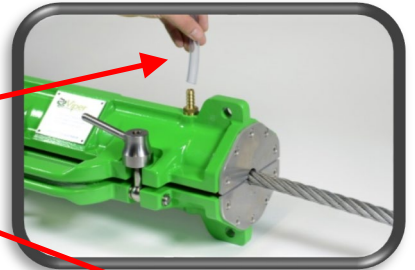
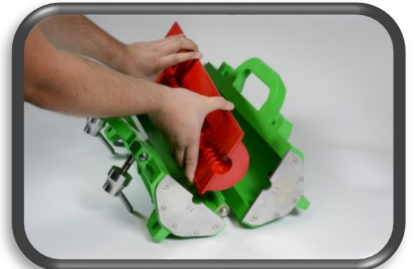



**14.** To secure the Viper lubricator collar in place, use the nylon ratchet straps and 'Bow' shackles.

- Secure one end of the ratchet strap to one of the lugs on the wire entry end of the lubricator collar via a bow shackle. Secure the other end to a suitable fixed position to prevent the lubricator collar from travelling with the wire rope. Replicate this using the second ratchet strap, bow shackle and lug on the lubricator collar.
- Note the ratchet strap is in high tension and strain during operation. Please ensure that all fittings are tightly secured prior to operation.
- The lubricator collar must be able to move laterally during operation to ensure even wire rope spooling on and off the rope drum.

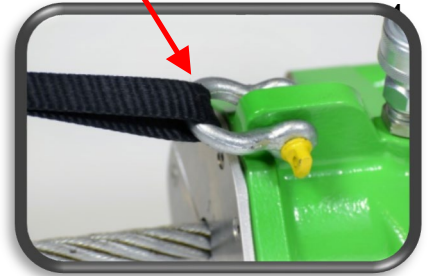

**15.** Connect the air supply to the air regulator unit fitted to the grease pump. Ensure that the air shut-off valve is off, preventing the air from reaching the pump motor. Set the air pressure regulator to 5.5 bar (80psi) and adjust up to 7 bar (105psi) if required.



***The Viper Maxi MK II Wire Rope Lubricator is now assembled and ready for use.***

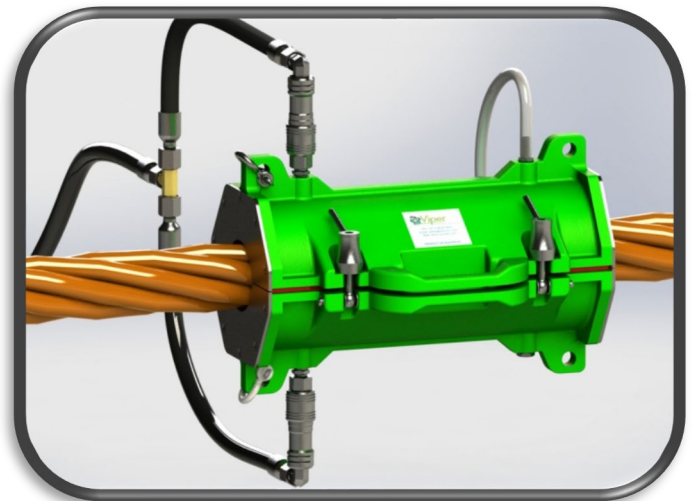

## 5.0 Ratchet Strap Buckle Assemblies - Ref: AW107

### Basic Steps of Operation

#### To Tighten:

1. Secure Hooks on either side of load.
2. Insert free end of strap through slot A and pull through excess webbing
3. Push down and pull up handle B to work the ratchet strap till strap is as tight as possible.
  - a. Do not over tighten, as the straps are only designed to maintain position of the Viper Collar.
4. Ensure at least 2 to 3 revolutions of webbing are around centre cam A.
5. Push Handle B down to lock your Tie-Down.

#### To Release:

1. Pull back on quick release C and hold.
2. Pull handle B up and over to a fully open flat position.
3. Pull tie-down up to loosen strap and remove from slot A.

To be used as a guide only

Please note: Lubricate all moving parts on a regular basis.

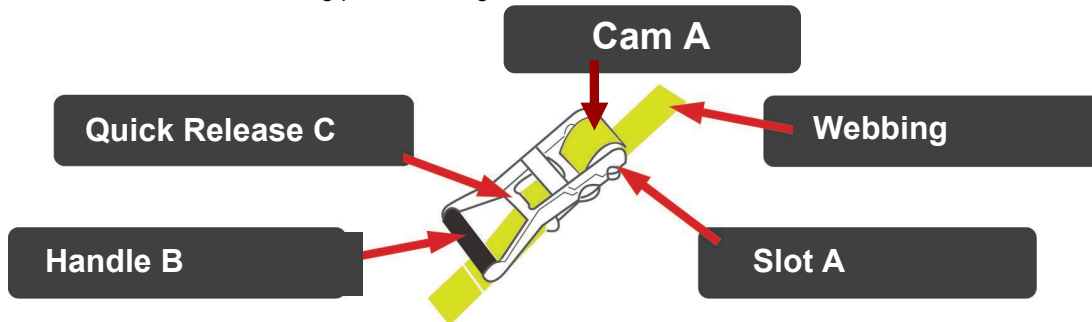

### Use and Care Instructions – Webbing Load Restraint Systems Ref: AW116

**Use:** The selected lashing system should be both strong enough and of the correct length for the mode of use. Good lashing practice should always be followed; the fitting and removal operations of the lashing should be planned before starting a journey. The lashing should be suitably pre-tensioned and regularly checked.

#### **CAUTION: NOT TO BE USED FOR LIFTING**

**INSPECTION:** Web lashings and any fittings or coupling components attached should be subject of frequent visual inspection and regular examination by a competent person. Web lashings shall be withdrawn from service if there is cause to doubt fitness for use.

**MARKING:** Use only legibly marked and labelled web lashing.

**OVERLOADING:** Lashing systems should not be overloaded. Mechanical aids such as levers or bars should not be used unless they are specifically designed for use with the device.

**PROTECTION:** The webbing and labels should be protected against friction, abrasion and damage from load with edge radii less than twice the webbing material thickness, using protective sleeves or corner protectors.

**SERVICEABILITY:** Normal wear and tear can reduce the strength of the webbing assemblies. If webbing is damaged by more than 10% of its original state due to abrasion, cuts, prolonged exposure to sunlight or chemicals then it should be replaced. Similar, if tensioning devices such as hand ratchets and end fittings are damaged by wear or corrosion they should be replaced.

**RESPONSIBILITY:** It is the responsibility of the owner, the driver and the person in charge of the loading to ensure that a vehicle's load restraint and attachments, and the load securing equipment, are serviceable and strong enough for their application.

**NOTE:** The user of this strap assumes all risk and liability for its handling and use.

*For further information please refer to the RTA 'Load Restraint Guide'.*

## 6.0 Viper Maxi MKII WRL Operating Instructions

With the Viper Wire Rope Lubricator assembled and mounted correctly as per the previous instructions, you are now ready to operate the system and lubricate the nominated wire rope.

1. Make sure the high pressure lubricant flow control valve is closed (turn clockwise to close).
2. Open the air supply to the lubricant pump via the air control valve. The pump may start to pump for a short period but will stop as the lubricant reaches the closed lubricant flow control valve. Check that the air regulator is set to 5.5 bar (80psi) and adjust up to 7 bar (105psi).
3. Open the high pressure lubricant flow control valve slowly by turning anti clockwise and proceed to fill the installed seal with lubricant. Once lubricant appears at the wire rope entry point or in the overflow drain line, close the lubricant flow control valve by turning clockwise.

Page | 16

*THE VIPER IS NOW CHARGED AND READY FOR OPERATION.*

4. Start the wire rope moving through the Viper collar and then slowly open the lubricant flow control valve. Continue to open until an even coating of grease is visible on the wire rope exiting the collar.
  - Speeds of up to 2,000 metres per hour are possible but this depends on several factors, including the rope size, speed and specific lubricant in use.
5. The lubricant flow control valve should be adjusted as required to provide the correct lubricant flow rate into the lubricator collar and thereby onto and into the wire rope.
  - If the lubricant flow rate is too high lubricant will begin leaking out of the Viper collar at the rope entry point or from the excess lubricant clear hose.
  - Reduce the lubricant flow by turning the flow control valve clockwise. Alternatively increase the wire rope speed through the lubricator collar until the correct amount of lubricant appears on the wire rope.



6. Visually inspect the wire rope as it exits the collar to observe if full lubricant coverage is being achieved.
  - If insufficient coverage is being achieved, increase lubricant flow rate by adjusting the lubricant metering valve anti clockwise until an even coating occurs.
  - Alternatively reduce the rope speed until an even lubricant coating occurs.
7. If lubricant leakage occurs around the collar, check the collar is correctly tightened and seals are fitted correctly.
8. An even balance between lubricant volume and wire rope travel speed is required to achieve an even lubricant film combined with optimum penetration.
9. Once the optimum lubricant coverage is achieved, run the complete rope at a consistent speed though the Viper.
10. Note that the Viper collar with flexible seals is not a pressure vessel and is not designed to hold pressure. The grease pressure is generated by both the pump and the action of the rope travelling through the lubricant chambers in the seal. The Viper grease pump should not be operated with the wire rope stationary.

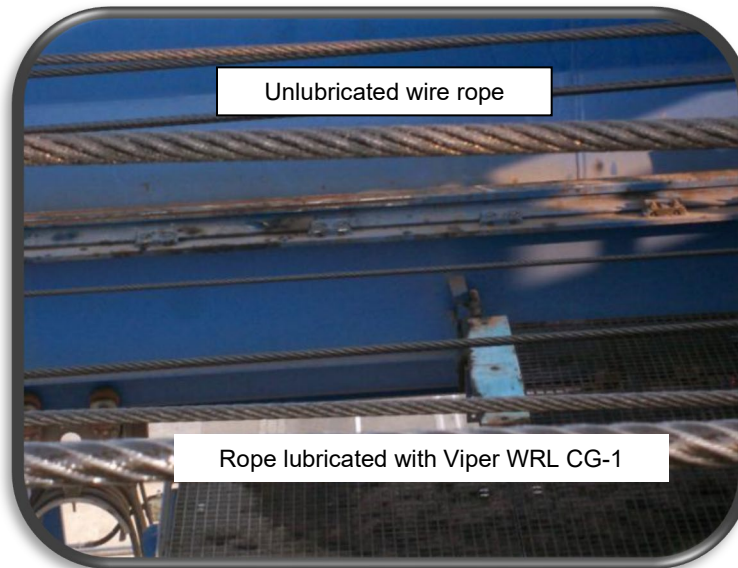

## 7.0 Lubricant Penetration

To inspect internal lubricant penetration, use a sharp spike or heavy-duty screwdriver to open up the wire rope. Alternatively, two pipe wrenches secured one metre apart, and rotated in opposite directions will allow visual inspection.

Lubricant penetration to the wire rope core is often difficult due to the following:

Page | 18

- Wire rope design, particularly anti-spin and locked core wire ropes.
- Dirty or contaminated wire ropes.  
(Use of a Viper Wire Cleaner is recommended)
- Ropes contaminated with solid used lubricant coatings.  
(Use of a Viper Wire Cleaner is recommended)

During the wire rope operation, the rope movement onto the drum and over sheaves is known to assist with the lubricant penetration.

If an NLGI#2 grade grease is used it may be necessary to pre-heat the lubricant at ambient temperatures below 5 degrees C (41 F) to ensure adequate penetration. Check with lubricant suppliers for method of pre-heating and individual lubricant specifications. Be sure that the lubricant used will adequately protect your wire rope from corrosion and wear.





## 8.0 Equipment Specifications

### Drum Pump

	Standard Kit	High Flow Kit
Maximum operating air pressure	8 bar/120 psi	8 bar/120psi
Pump ratio	45:1	50:1
Flow rate approximately	4,500 grams per min	13KG per min
Volume of compressed Air	250L/min at 7 bar	1.9 mt <sup>3</sup> /min at 8 bar

Page | 19

Guideline pressures are as follows:

Air Pressure for all Wire Rope Diameters 5.5 - 7 bar (80-105 psi)

### Viper Collar

- Cast aluminium construction with enhanced mechanical properties and excellent resistance to corrosion, heat treated to T6.
- Lugs tested to withstand 800kg of resistance.
- Coating: 3 coat treatment.
- Salt – Spray Resistance to ASTM B117-73 - 2,000 hours
- Humidity Resistance to ASTM D2247 - 1,000 hours

### Seals

- Estimated average operational life – 10,000+ metres
- Shelf life 2-3 years (based on correct storage)
- Chemically resistant to commercially available mineral wire rope lubricants.
- The lubricator seals may be washed with a mild petroleum cleaner.
- Do not leave the seals to soak in cleaning fluid which may be detrimental to their composition.
- It is important to store the seals away from UV light. The seals will be harmed if left for extended periods in sunlight.
- Seals should be kept in a sealed plastic bag as supplied.

### Scrapers

- 5083 Grade Aluminium Alloy High resistance to corrosion and ideal for marine applications.

(Note: Lubrication Engineering reserves the right to change specifications as and when required.)



## 9.0 Trouble Shooting

1. **NO LUBRICANT ON WIRE ROPE AFTER START UP**
  - a) Check lubricant container content.
  - b) Check lubricator pump air shut-off valve is open.
  - c) Check air pressure on gauge.
  - d) Check lubricant control valve is open.
  
2. **INADEQUATE LUBRICANT COVERAGE**
  - a) Utilize lubricant drum heater or change to lighter viscosity if ambient temperature is 5°C or below.
  - b) Increase air pressure and hence lubricant flow, until correct quantity of lubricant is on wire rope.
  - c) Open lubricant flow control valve fully to increase lube flow.
  - d) Reduce wire rope speed to ensure complete coverage.
  
3. **TOO MUCH LUBRICANT ON WIRE ROPE**
  - a) Reduce volume of lubricant via the flow control valve.
  - b) Increase wire rope speed through the lubricator collar.
  - c) Use a combination of both.
  - d) Investigate type of wire rope lubricant used.
  - e) Measure rope diameter and ensure correct seals in use.
  
4. **LEAKING FROM COLLAR**
  - a) Tighten collar clamping screws
  - b) Check correct Viper seal is being used for wire rope size.
  - c) Check air pressure reduce if required.
  - d) Adjust lubricant flow rate from control valve.
  - e) Check condition of seals for any damage.



## 10.0 Safety Recommendations – Caution Level Rating

- Before installation of the wire rope lubricator onto the cable, ensure the work area is clean and safe to work in with adequate space around the cable where the Viper collar will be attached.
- Ensure buckles and straps, D shackles and attachment points used to anchor the Viper Lubricator are rated for a minimum WWL of 800 kg.
- Check hydraulic hose, couplings air lines and fittings for damage or wear, before connecting to grease pump and Viper lubricator collar. Carry out visual inspection of the Viper collar to ensure it has not been damaged during transport or handling. Damage to the casing that prevents it from sealing correctly will severely reduce the unit's ability to force lubricant into the ropes core and could be a potential safety hazard.
- Always ensure the return grease line feeds to a container of suitable size for receiving the excess grease from the Viper lubricator. Grease allowed to flow from the return line without being captured may cause a serious slip or environmental hazard.
- Note Lubricants vary in their hazard and environmental ratings. Please ensure Material Safety Data Sheets for all lubricants used with the Viper are kept in close proximity to the kit. Lubrication Engineering recommend a copy of the lubricant in use MSDS is kept in the Aluminium carry case for reference as required. Lubrication Engineering supply a copy of the Viper WRL Coating Grease CG-0 MSDS with any kits that include this product.



## 11.0 Safety Recommendations – Danger Rating



- Before attaching the Viper lubricator collar to the cable, you must ensure the cable winch control has been locked out and tagged. Serious injury or death may occur should the cable winching equipment be activated while the Viper Lubricator is being fitted to the cable.

Page | 22



- When the Viper Lubricator has been assembled, attached to the cable and anchored in position, the lubrication system can be activated. While in operation the grease pump can generate up to 5,500 PSI grease pressure. Under no circumstances should the Viper collar be opened, or the grease hose disconnected while under pressure as this can cause serious injury.



- While in operation the Viper Lubricator utilises both high pressure air, up to 120 PSI max and high pressure grease up to 5,500 PSI. Always wear appropriate PPE (Personal Protective Equipment) while carrying out the cable lubrication operation.



- Suggested PPE includes, safety glasses, leather gloves, safety boots, long sleeved shirts, high visibility vest, hard hat and hearing protection.



- Lubrication Engineering recommend to only use pumps, fittings, hoses and accessories supplied or recommended by Lubrication Engineers. All our components have been tested to ensure they will work safely and effectively for extended duty cycles. Using non-approved components may lead to unexpected failure of the Viper Lubricator and / or its components causing serious injury to maintenance personnel.



## 12.0 Viper Maxi MKII WRL Guarantee

The **VIPER Maxi MKII** Wire Rope Lubricator Kit and all the components are guaranteed for a period of 12 months from date of purchase against any fault of manufacture or material failure.

Fair wear and tear is expected of the unit and is not covered by this warranty. Tearing of the seals due to broken wires or other obstructions are not covered by this warranty.

Page | 23

Any parts to be claimed under warranty must be first returned to Lubrication Engineering for inspection prior to warranty being granted.

The Viper Maxi MK II is supplied and supported by -



26 Prince William Drive, Seven Hills,  
New South Wales, Australia, 2147

Web – [www.ViperWRL.com](http://www.ViperWRL.com)

Email – [sales@ViperWRL.com](mailto:sales@ViperWRL.com)

Ph: +61 2 9636 5655

Fax: +61 2 9636 8566

